

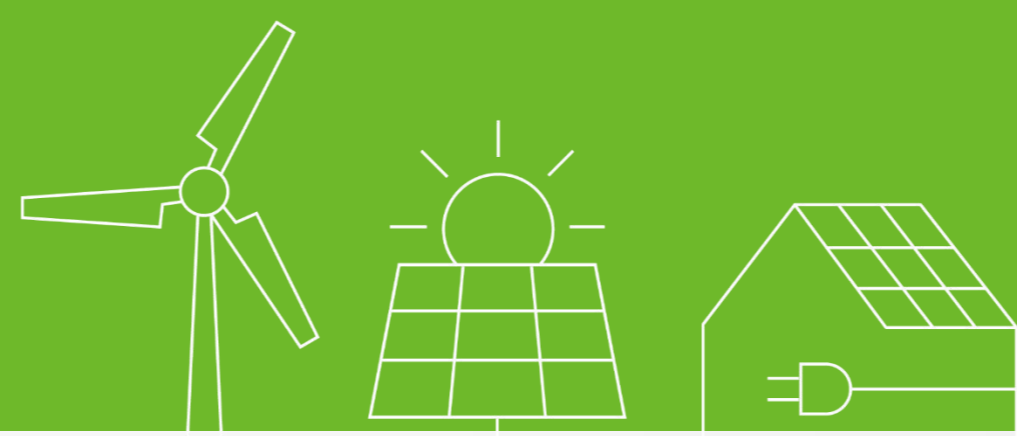

AXE 5.0L Modular Battery



2022

SHENZHEN GROWATT NEW ENERGY CO.,LTD





Dedicated to Becoming

The World's Largest Supplier of Smart Energy Solutions

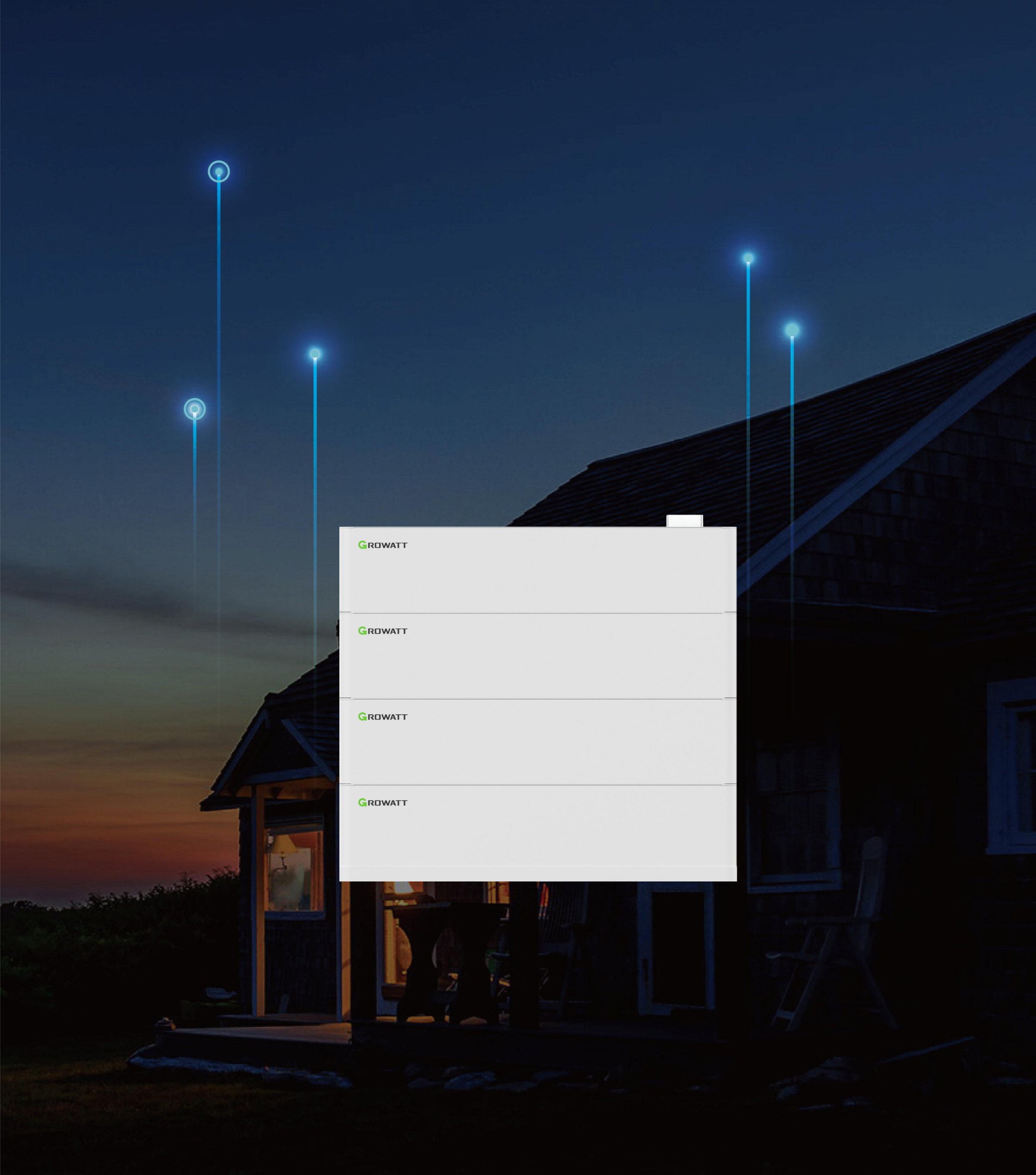

CONTENTS

- 01 Product Overview
- 02 Leading Features
- 03 Extreme Safe and Reliable
- 04 Advanced Technology
- 05 System Flexibility
- 06 Smart Management
- 07 Parameter

Product Overview

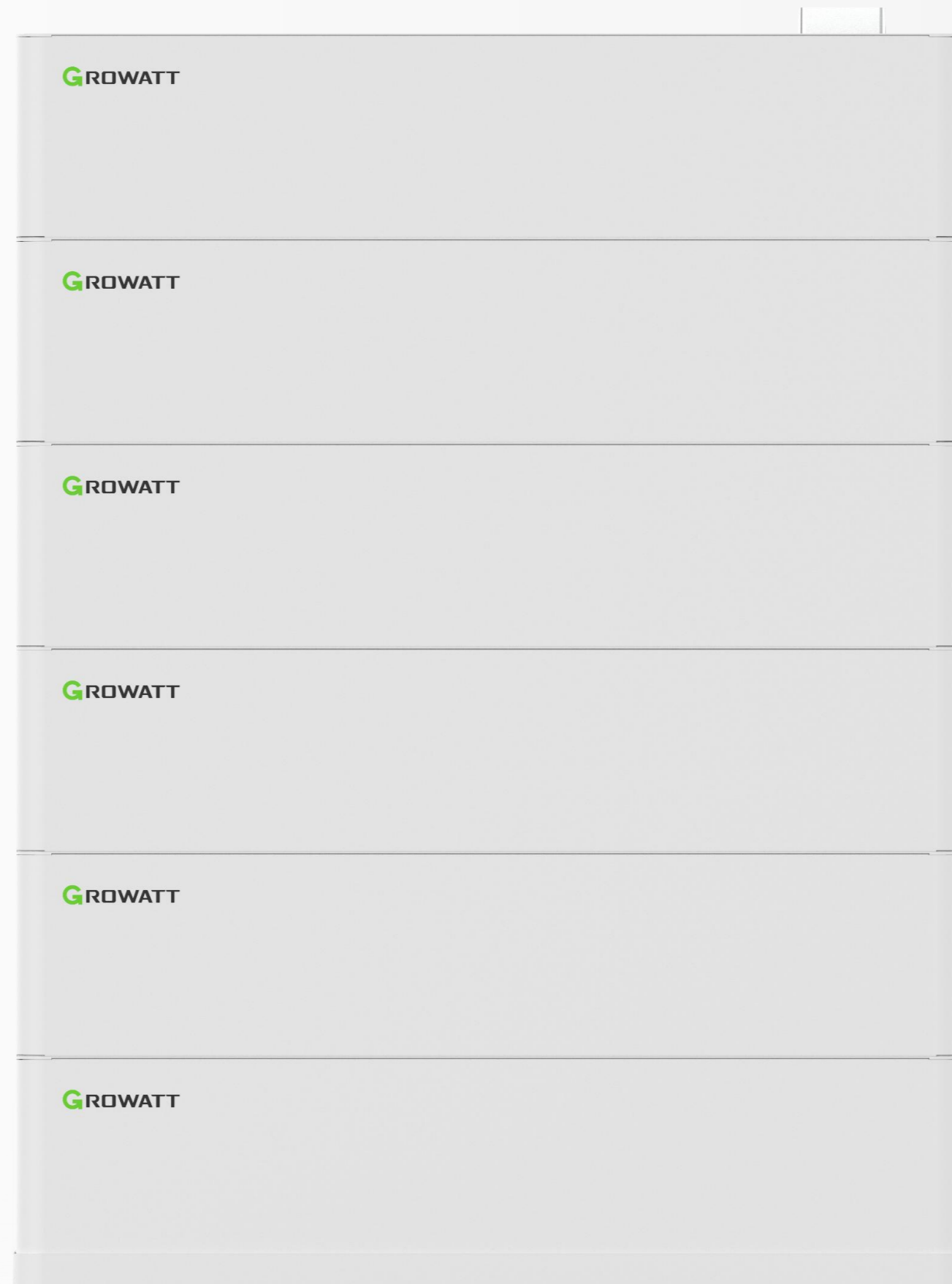

AXE Low Voltage Battery System

5.0kWh / Module

Single Cluster: 5.0kWh ~ 50kWh

Max. 8 clusters up to 400kWh

Leading Features

Natural Cooling

AXE 5.0L is designed with natural cooling providing optimum efficiency



Compact Design

Weight: 40kg

Dimension: 650*350*140 mm

Modular Design



Extreme Safe and Reliable

LFP is the most suitable chemistry for residential ESS

Better

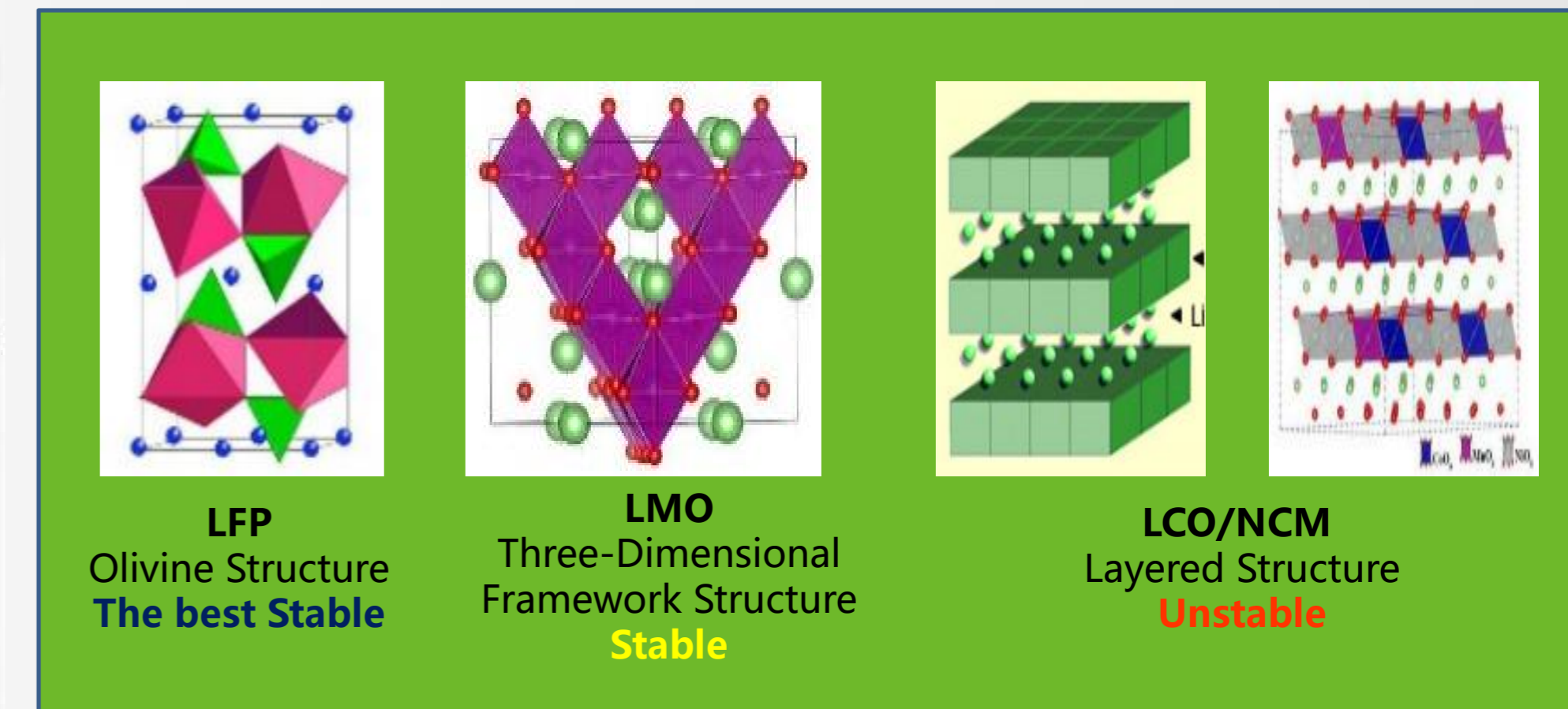
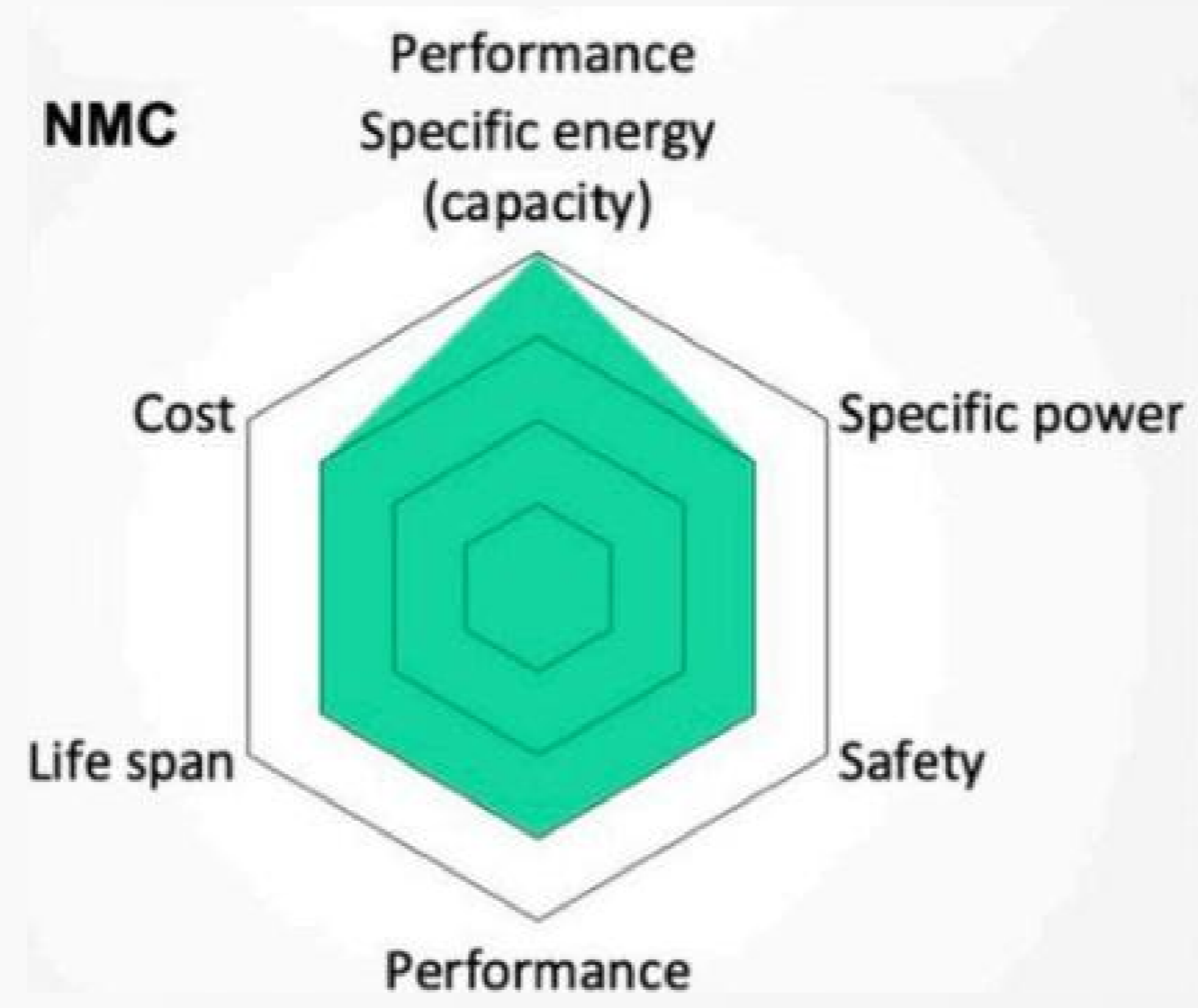
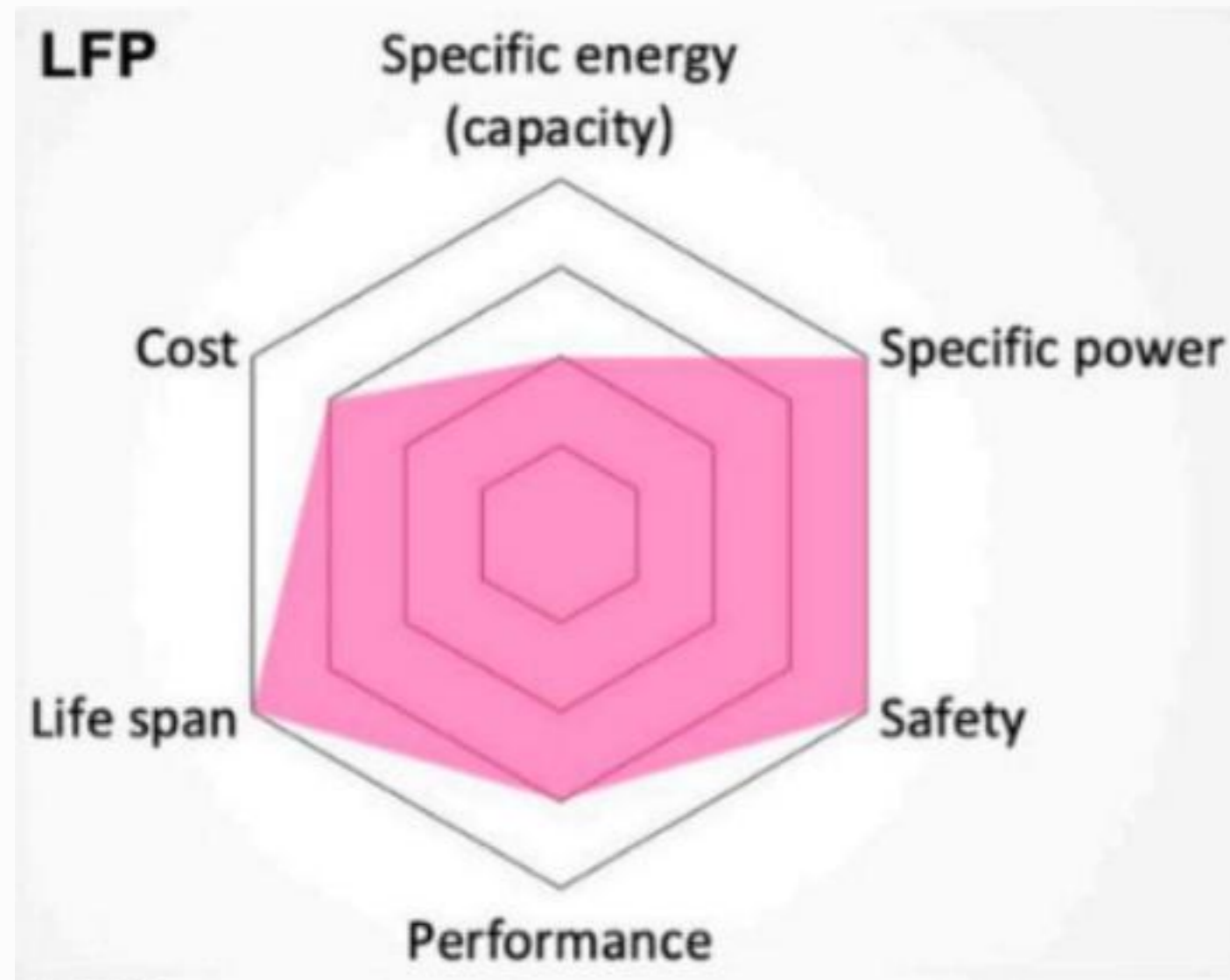

LiFePO₄ chemistry features stable structures and its thermal runaway temperature is over 480°C. That's 100% higher than NCM chemistry

Extreme Safe and Reliable

Cell Monitoring

Not only monitor battery module data, but also monitor each cell security status

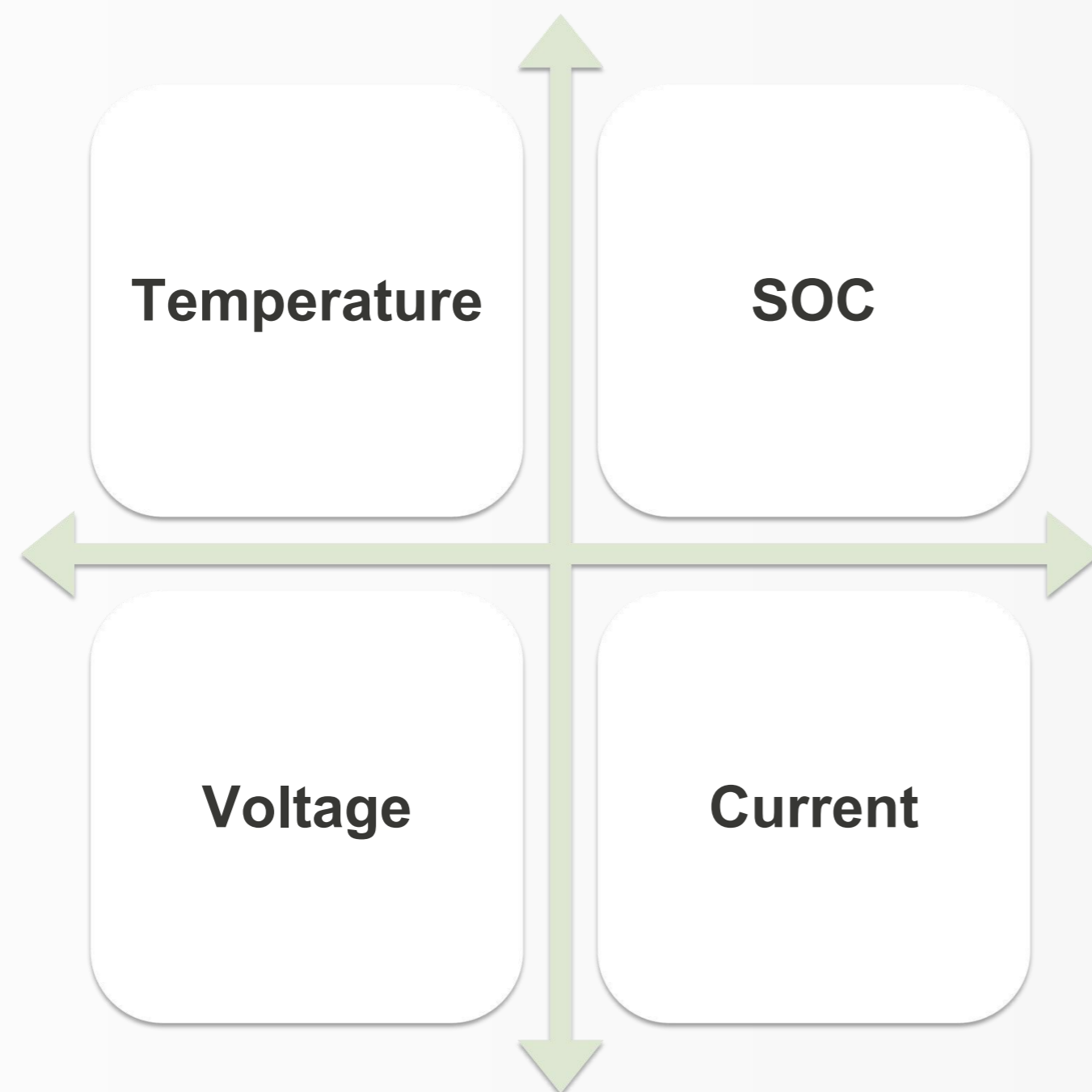

Full Protection

Provide full-protection for the whole battery system

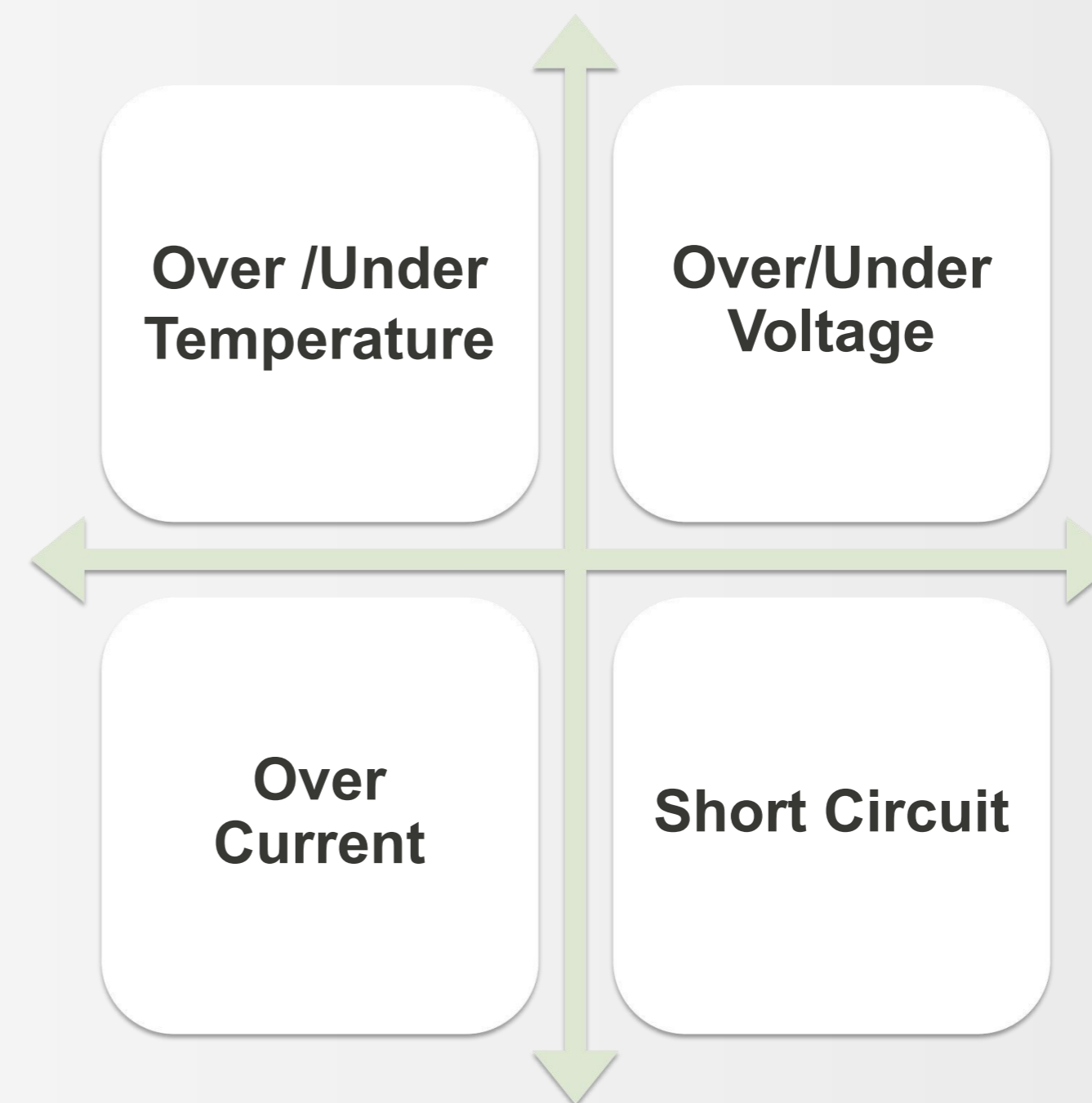

Advanced Technology

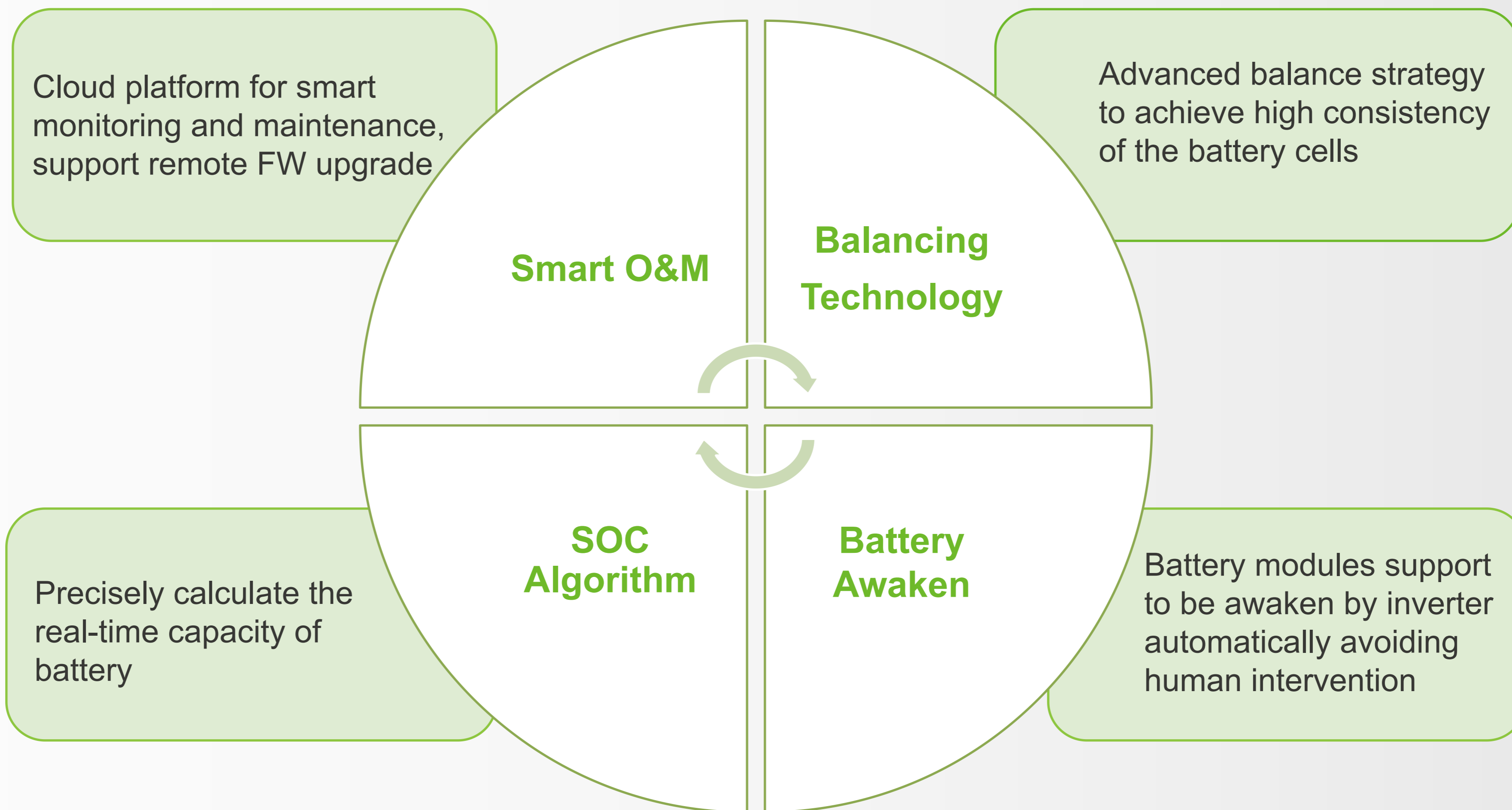

System Flexibility

Easy installation by stacked modular design without any cable connection

Quick connection from battery system to inverter

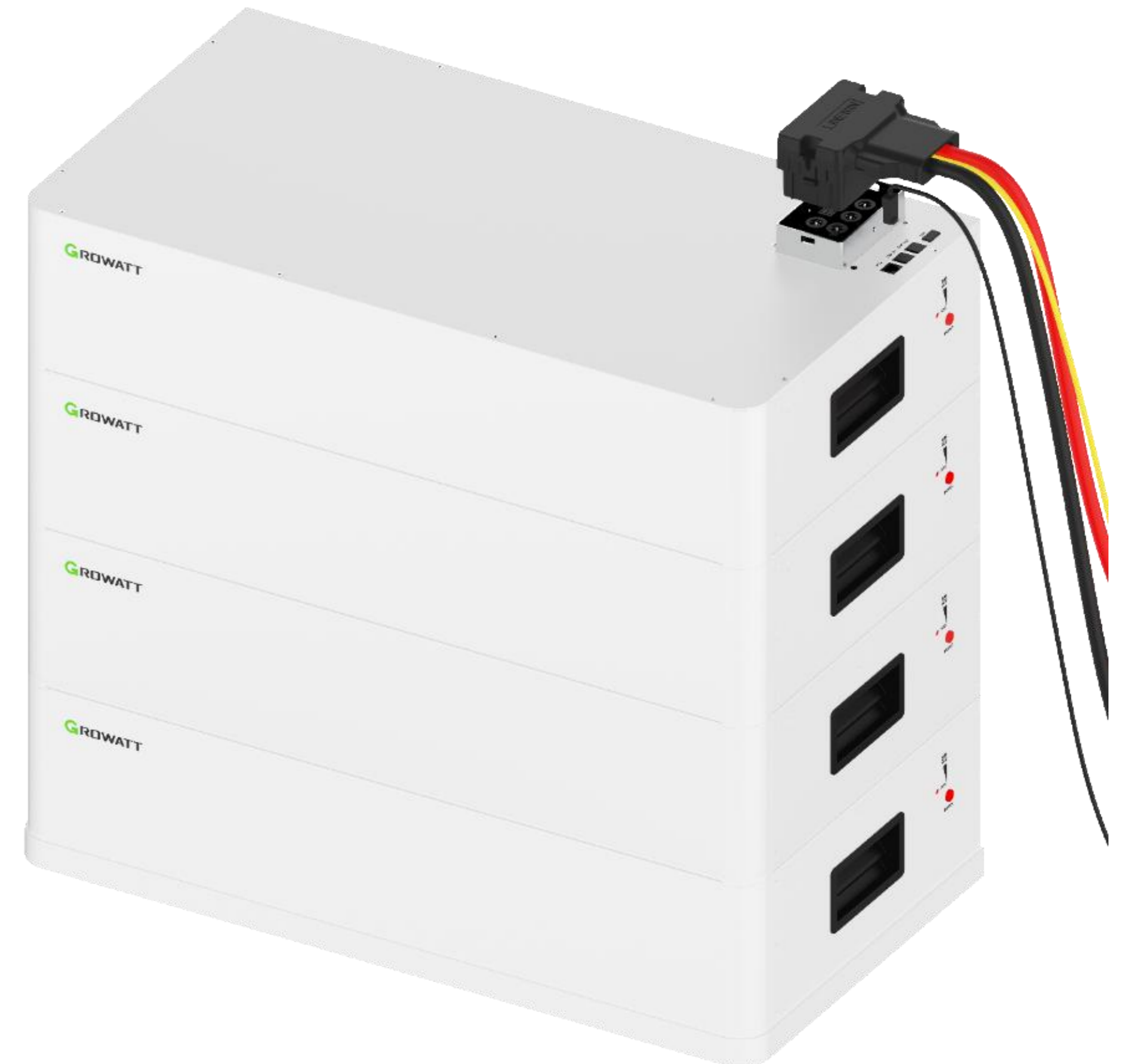
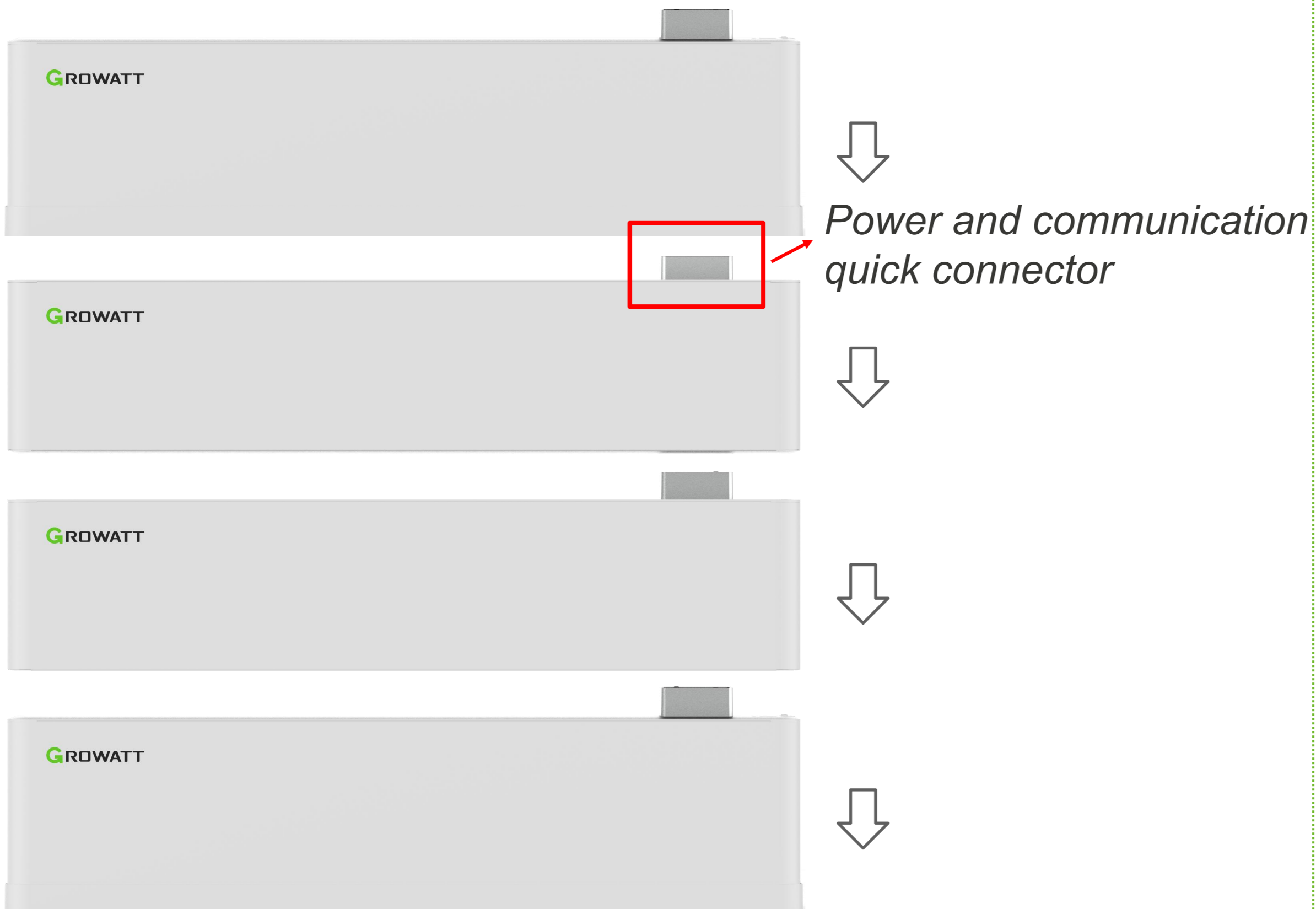

System Flexibility

Compatible with Different Storage Inverters

Hybrid Inverter



SPH 3000-6000/SPH 3000-6000TL BL-UP

Off-grid Inverter



SPF 3500-5000ES



SPF 3000TL LVM



SPF 3000T HVM-G2

* The compatible inverter list in detail please consult with sales.

System Flexibility

Supporting max. 4 clusters in parallel

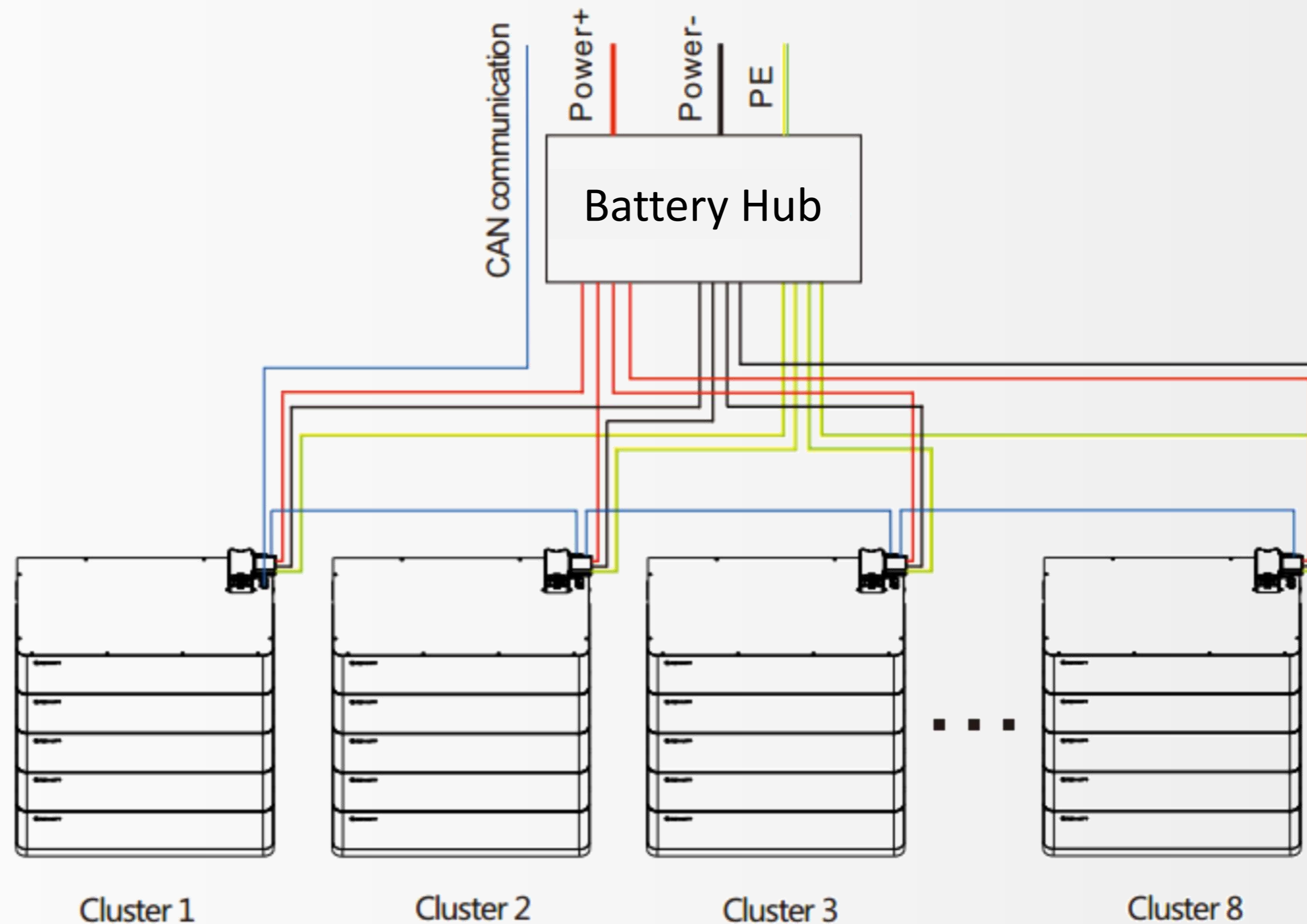

*GROWATT Battery Hub supports 4 clusters in parallel, more than 4 clusters application requires the installer to prepare the combiner box by themselves.

System Flexibility

Whole System Service

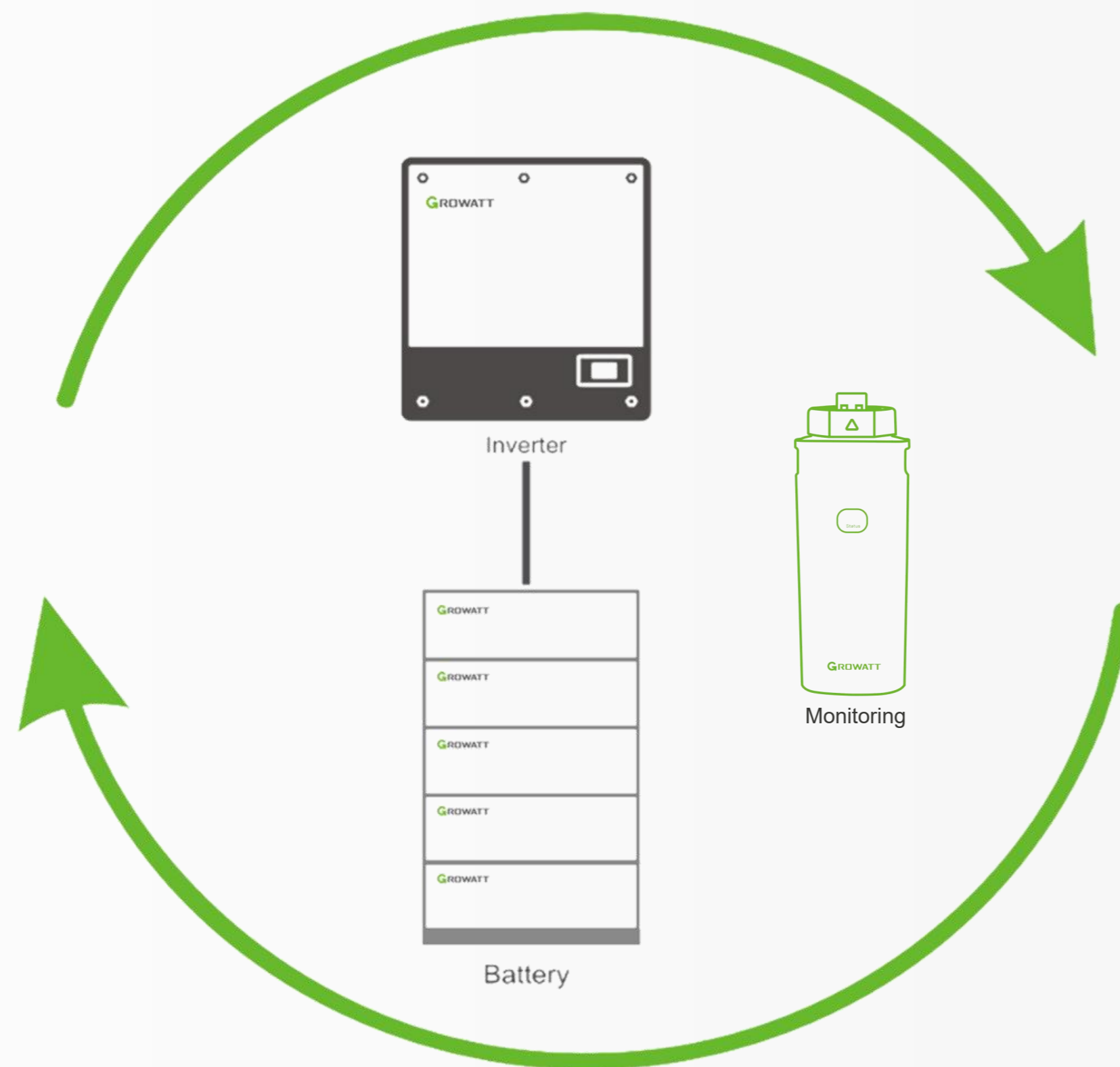

Complete Equipment Supply

Inverter, Battery and Monitoring,
Compatibility with lithium battery

Whole System Guarantee

Guidance and help of the whole system,
Warranty for all devices,
Professional and local service team

Smart Management

Real-time data upload status. System states under observation.
Frequent transfer of lost data after recovery

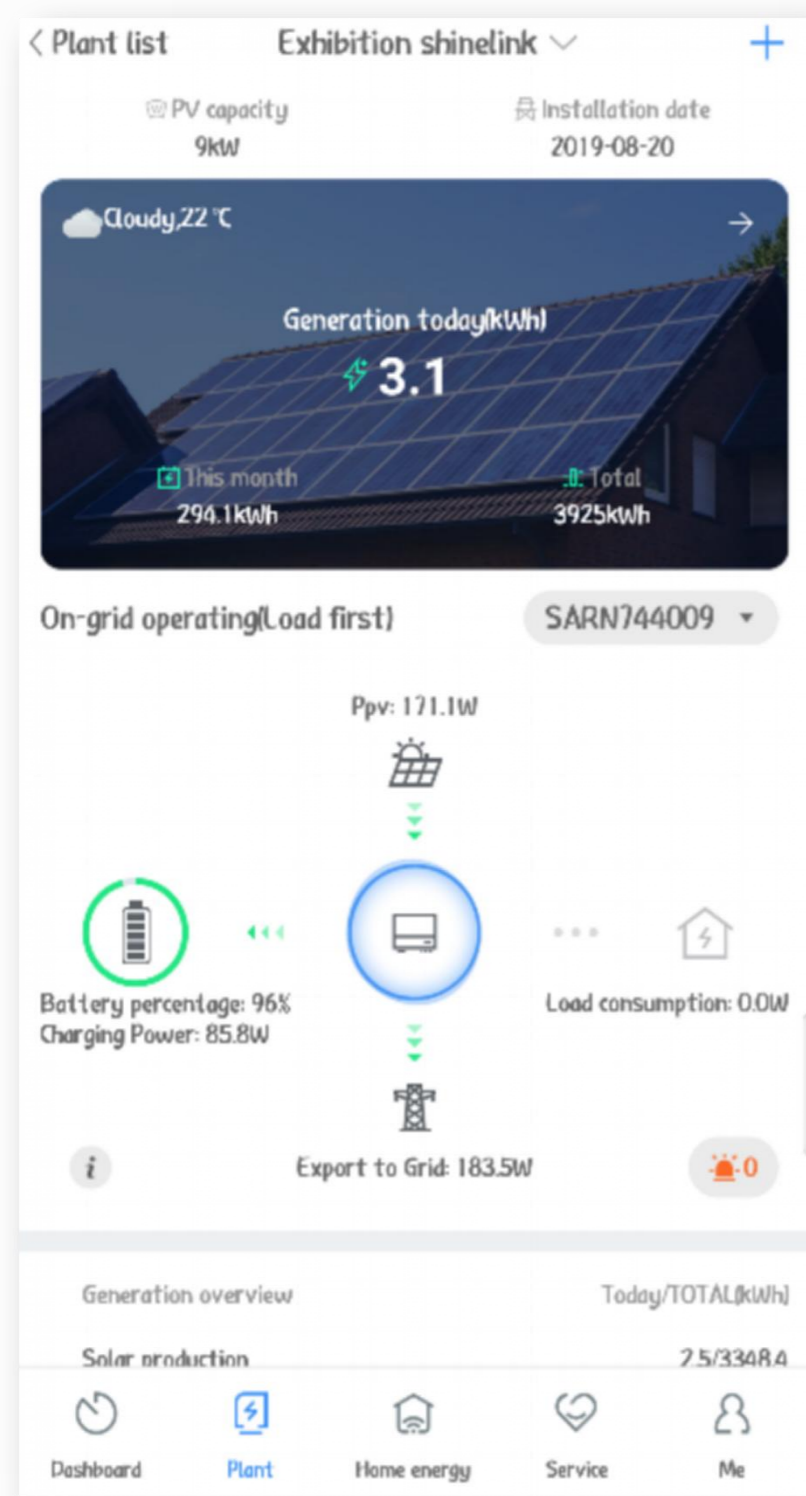

ShinePhone App

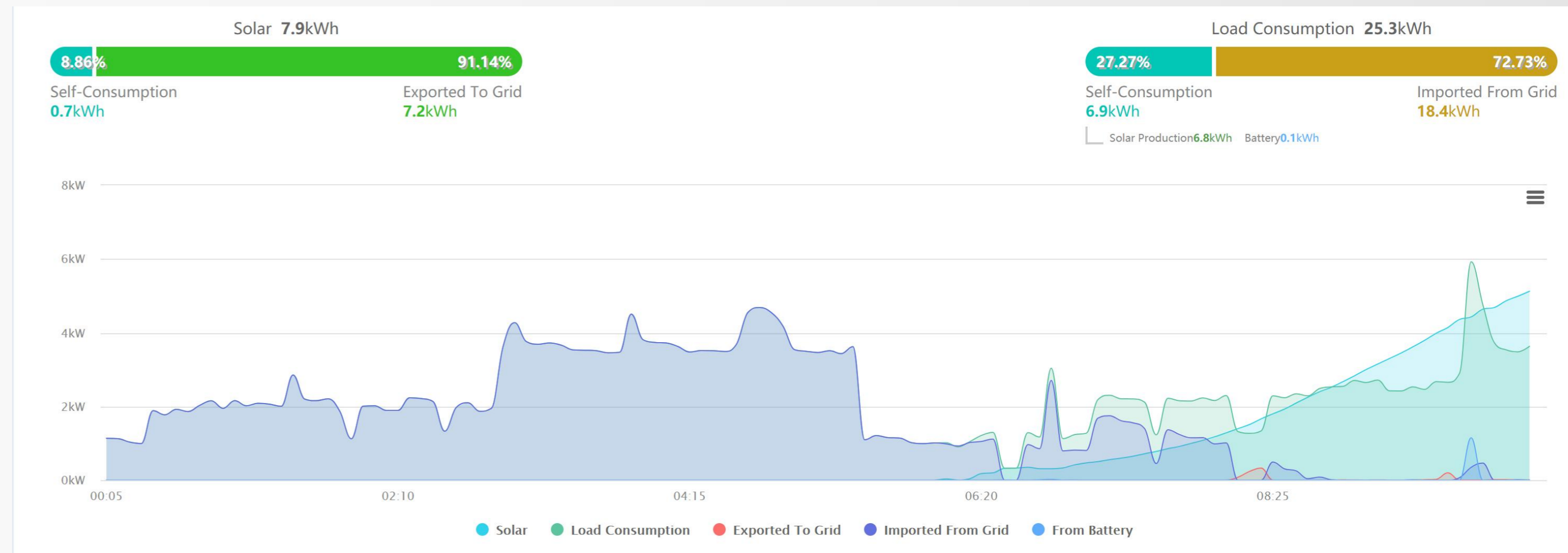
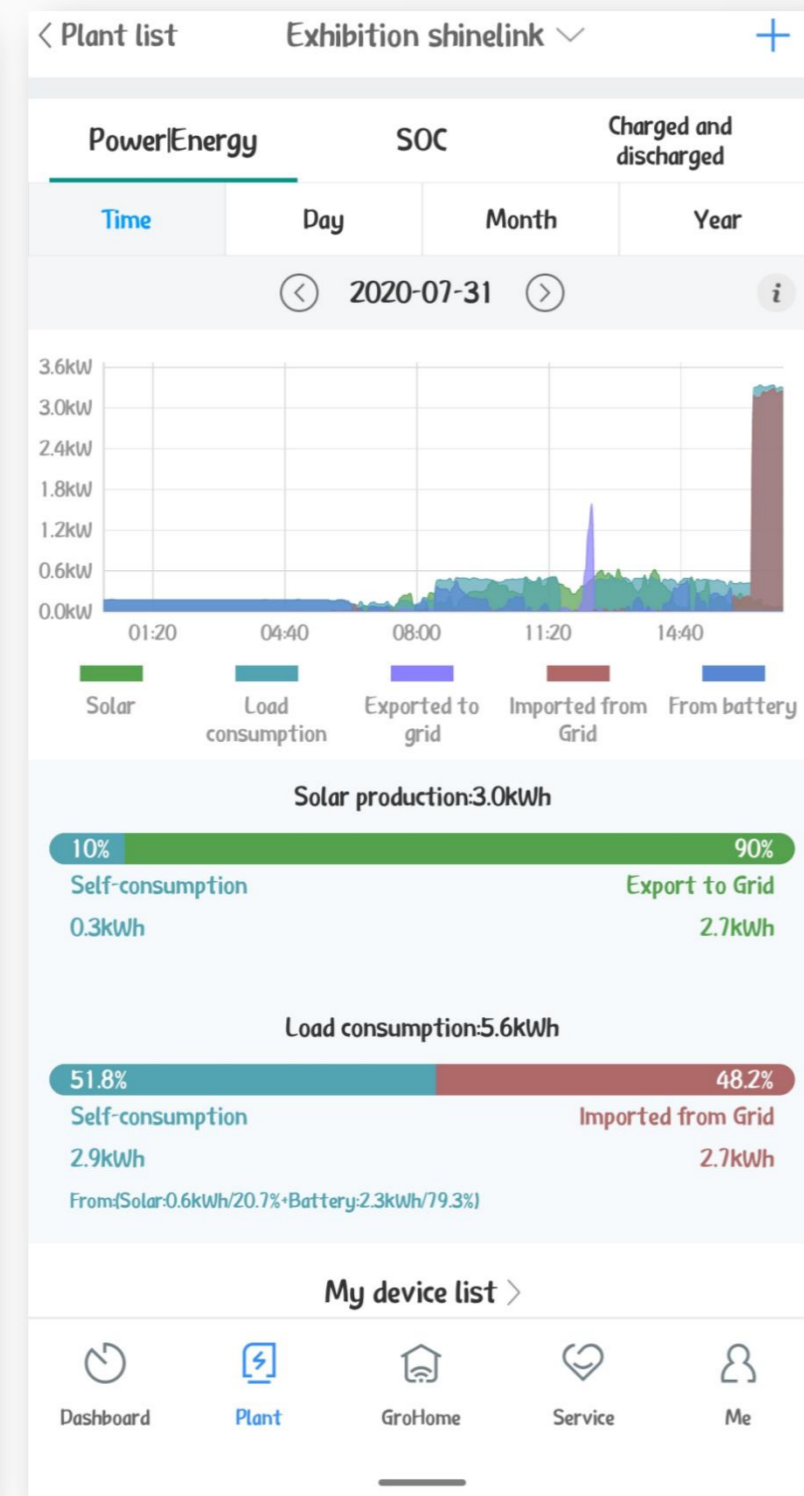

Server Monitor

Smart Management

Online Smart Service (OSS) System

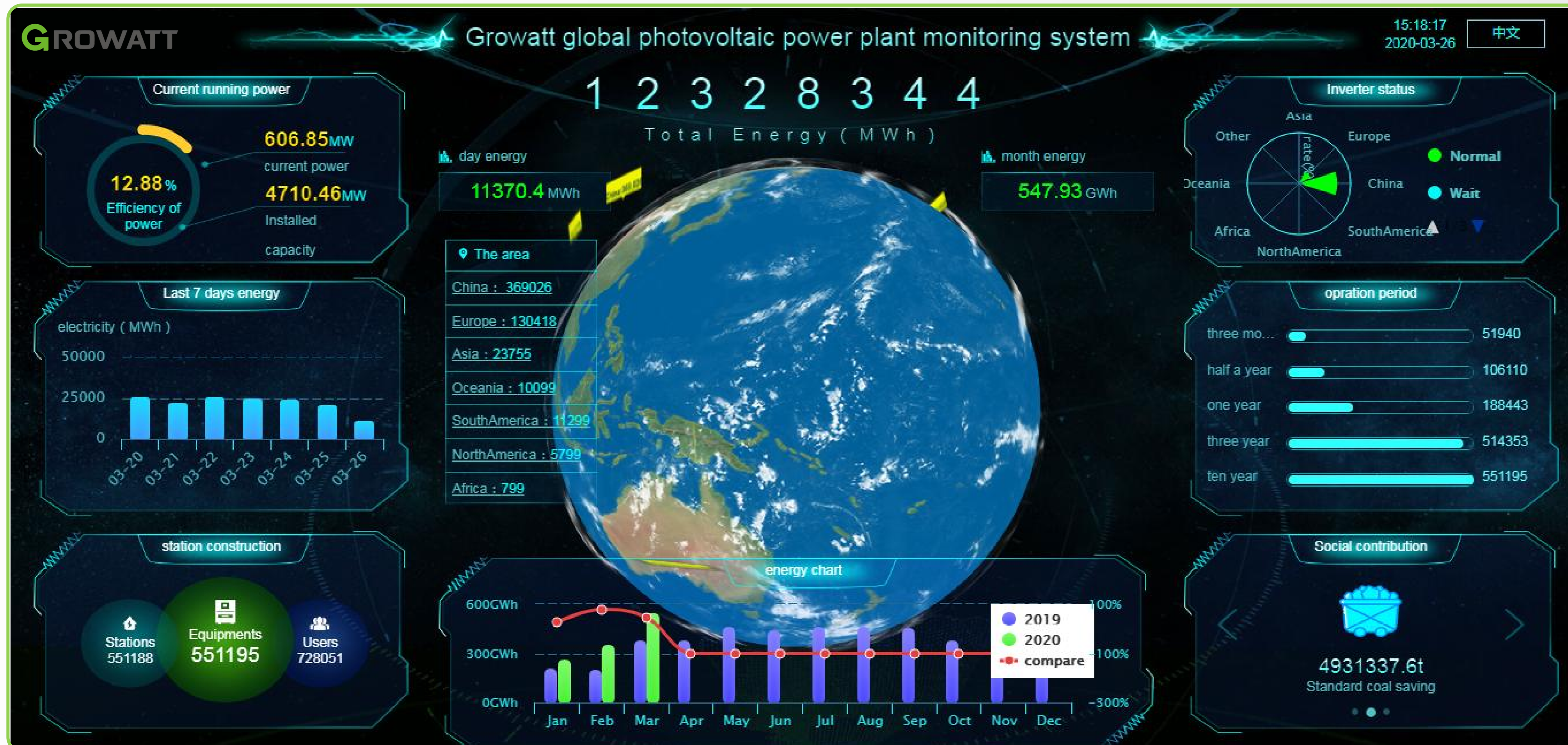

Online failure reporting

Remote parameter setting

Remote firmware upgrading

No need site travelling

Reduce maintenance cost

Parameter

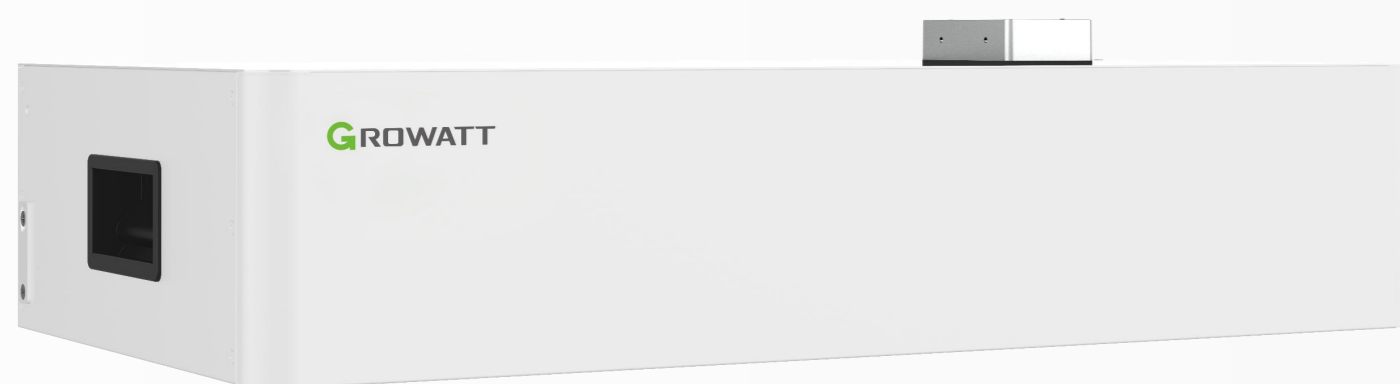

Battery System	Single AXE 5.0L
Total energy	5.0kWh
Usable energy	4.6kWh
Capacity	100Ah
Battery pack connection	1 ~ 10 packs in parallel
Battery cluster connection	1 ~ 8 clusters in parallel
Nominal voltage Range	51.2V (48-57.6V)
Charging/discharging current	60A
IP degree	IP 20
Operation temperature	0 ~ 50° C
Dimension(W*D*H mm)	650*350*165
Weight	45kg
Communication	CAN
Warranty (10 Years)	Yes

•Detailed information please refer to AXE LV Battery system datasheet

THANKS



Copyright© 2021 Growatt New Energy CO., LTD

All Rights Reserved. The information contained in this document is only for reference purpose and subject to change by company officials.

